

Minicrane Junior : The World's Most Versatile Lifting Machine



Model: Junior

Winch Capacity: 1,950 lbs

Hook Capacity: 1,950 lbs

Fork Capacity: 1,950 lbs

Glazier Capacity: 1,000 lbs

Robot or Jib Capacity: 1,000 lbs

Reach: Industry leading reach with below grade capability.

Battery Power: 24V 435Amp-Hour

Weight: 4,275 lbs

Steering: Rear Wheel

Charger: On-board 110 Volts AC

Proportional Controls: Electric Joystick for

Proportional Lift and Extend. Includes 2-Speed HI/LOW switch for precise slow speed control.

Drive: Rear Wheel Hydraulic Drive with Joystick and Speed Dial for precise control.

Rated Load Limiter: Displays rated load and actual load. Stops when rated load is reached. Detects which attachment is installed and automatically adjusts load parameters.

Progressive Function Control: Adjusts the maximum drive and lift speeds to limit unsafe operation based on the following:

- Steering Angle (Drive slow with tight radius)
- Boom Height and Reach
- Lifted Load (Slow when closer to limit)



Radio Remote Controls

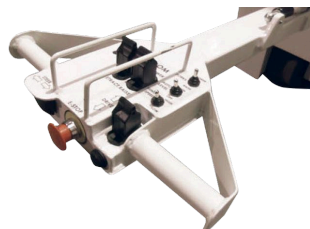

Walkie Handle

LOAD CAPACITY CHARTS

** MULTIPLE PATENTS PENDING**

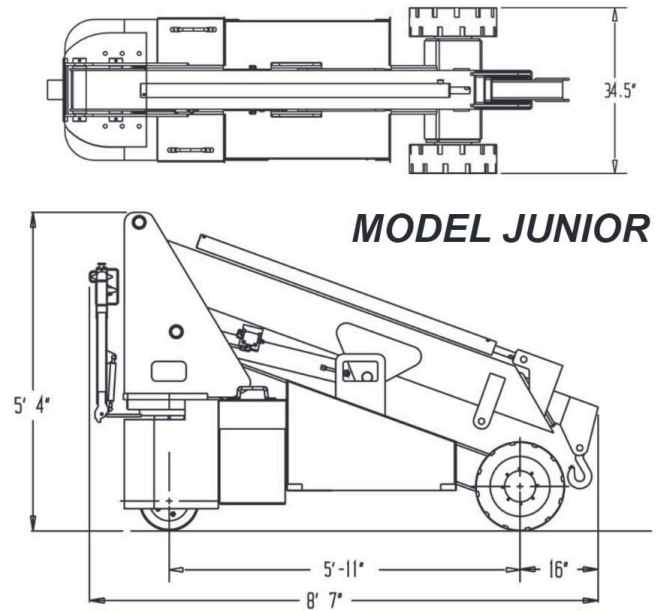
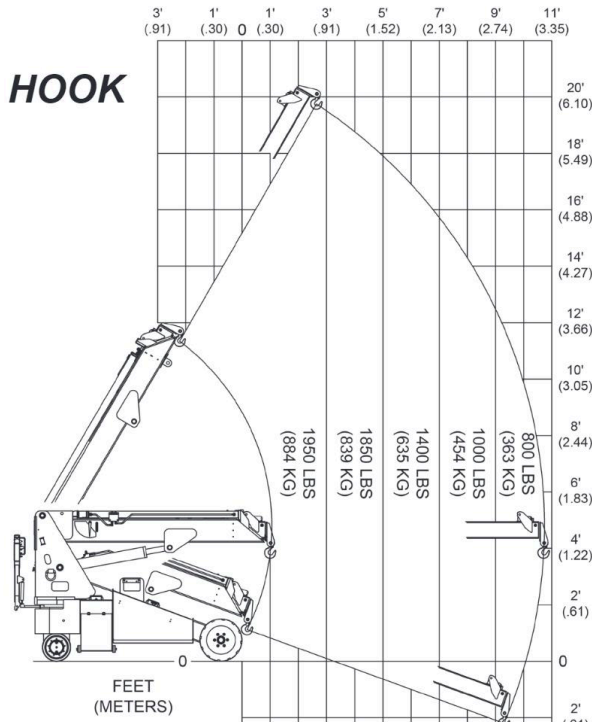

MODEL JUNIOR

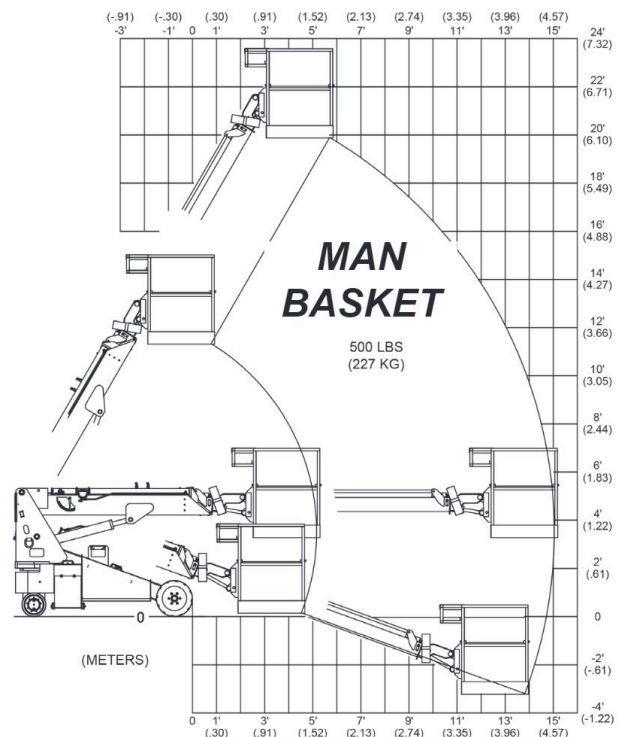
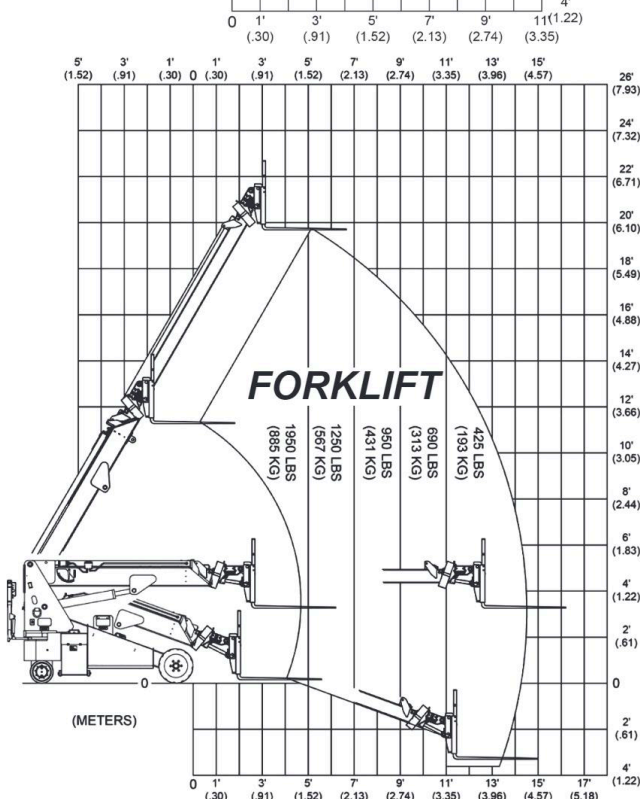

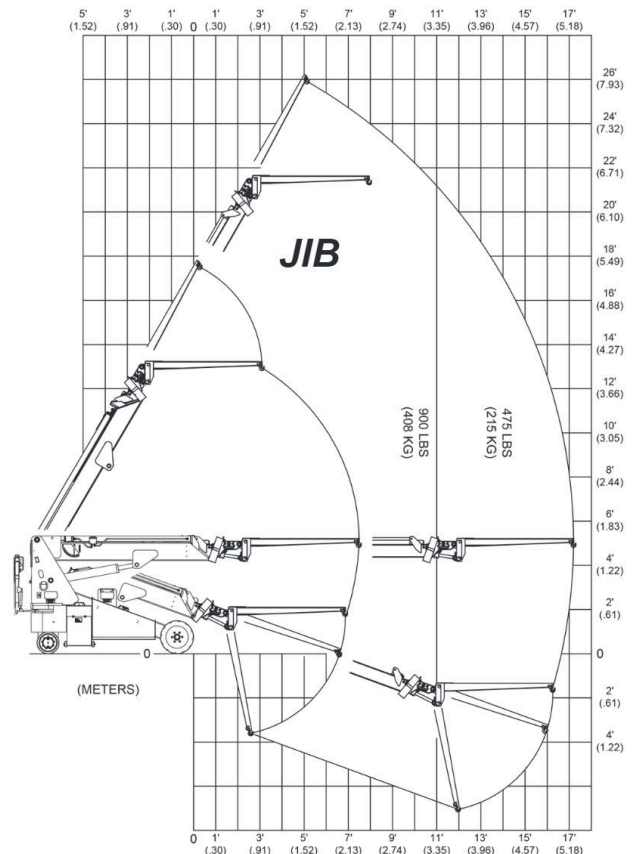
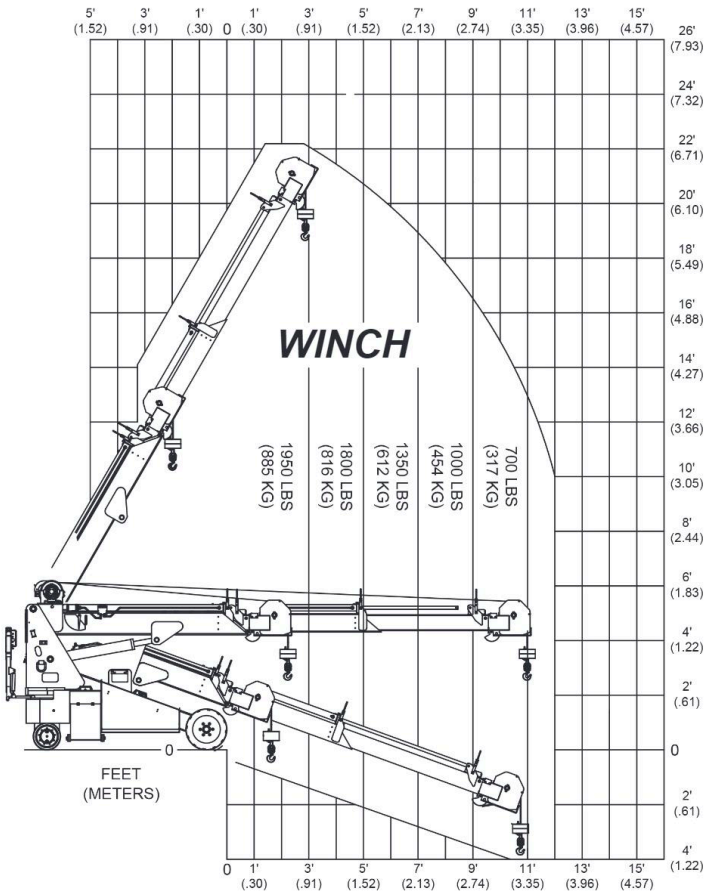
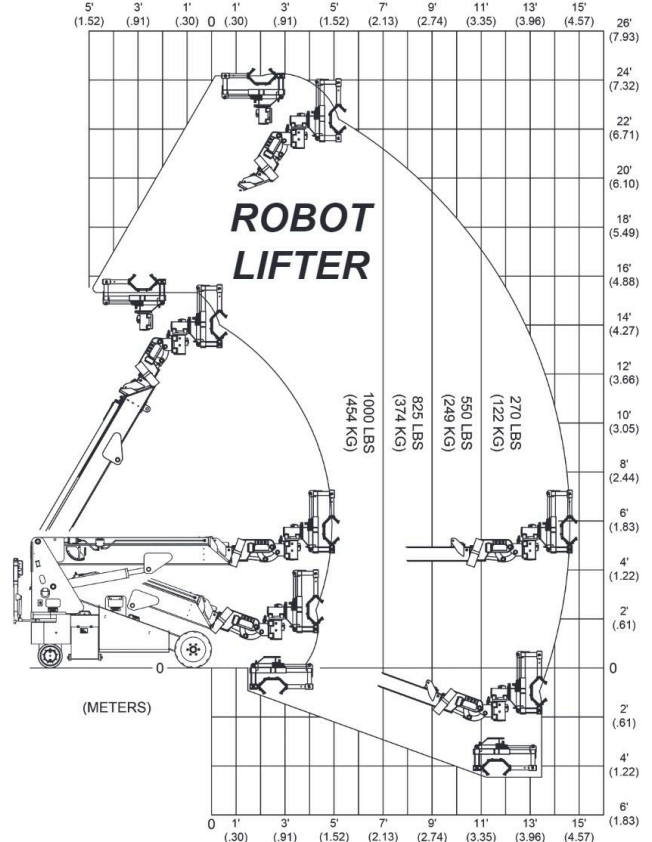
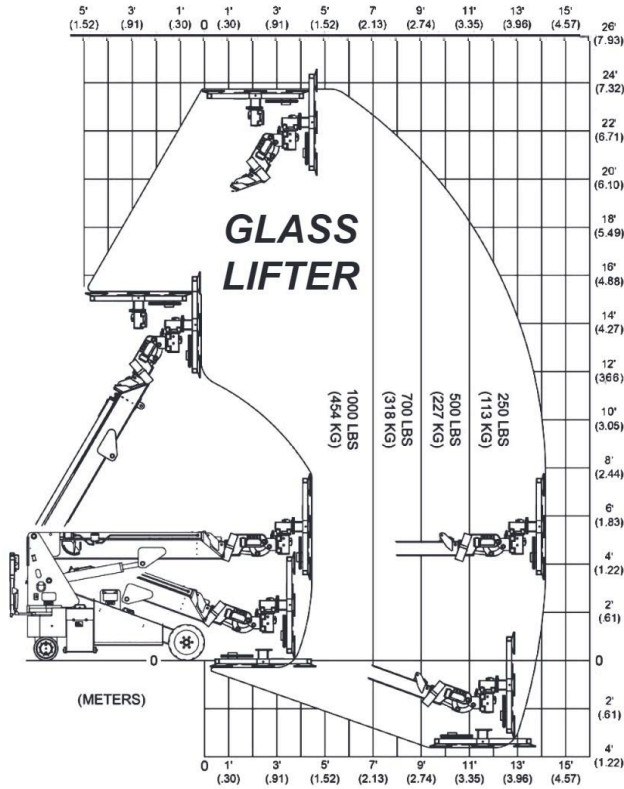

Multiple Attachments



Glass



Man Basket



Robot



Hanging Glass



Hoist Winch

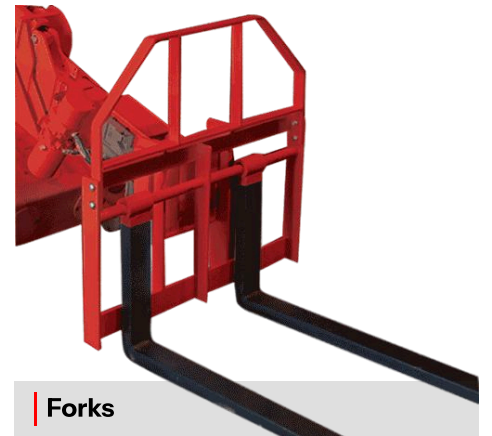

Forks

Features



Rated Load Limiter
Automatically detects attachment and adjusts loading parameters.



Removable Battery Box
For multi-shift operation.
Patented design loads without external sources.



Optional Stabilizers